

HEAT EXCHANGER TECHNOLOGY

The versatile, instant hot water, high pressure, hydraulic separator.



CASE STUDY

AIR APARTMENTS EASTWOOD, SA

Challenge

Air Apartments on Greenhill Road is one of Adelaide's premium residential apartment towers. Facilities include a gymnasium, 25m lap pool, spa and sauna, and family entertainment area.

The client wished to utilise the existing Raypak mechanical plant to provide domestic hot water from the basement

with pressure requirements exceeding those of storage tanks.

A pair of Rheem Crossflow hot water delivery systems were manifolded with RT storage tanks providing segregation between domestic hot water and the mechanical heating system, high pressure zones capability, accurate temperature control, and connectivity to the building management system.

Hot Water Solution

Total hot water plant installed across the precinct included:

- 2 x Rheem Crossflow systems manifolded
- 3 x Rheem RT1000 stainless steel storage tanks



RHEEM CROSSFLOW®

SUITED TO COMMERCIAL APPLICATIONS, PARTICULARLY MULTI-STOREY CONSTRUCTION



HIGH PRESSURE



CERTIFIED



BMS CONNECTIVITY



WASTE HEAT RECOVERY



SMALL FOOTPRINT

ROOFTOP PENTHOUSE VS. ROOFTOP PLANT

High working pressure of 1400kPa, the result of its hydraulic separator design, means Crossflow can be located in the basement of tall buildings - leaving rooftop space available for more profitable allocation.

MORE POWER FOR THE SPACE

Variable speed pumps accurately match the required energy load to deliver tankless, on-demand hot water with exceptional temperature control.

Crossflow uses 25% of the space of an equivalent storage-based system.

LOW PRESSURE LOSS

Crossflow exhibits exceptionally low pressure drop, so there's minimal impact on building design.

BUILT-IN REDUNDANCY

Designed with dual-head pump and twin heat exchangers that share the load, allowing isolation for maintenance, with no interruption to supply.

HIGHLY EFFICIENT HEAT EXCHANGE

Can be used with all heating types, solar, heat pump, gas, electric - as well as waste heat.

BMS AND SCADA CAPABILITY

Pump offers data transfer and monitoring capabilities to BMS or SCADA systems by an add-on CIM module suitable for Modbus, Bacnet and Lonworks.

MORE KEY FEATURES

- Factory assembled and tested on a hot dip galvanized frame
- All fittings and pipe work are 316L stainless steel
- Can be used as a hydraulic separator for solar, Co-gen and PP-R systems
- Grundfos Go remote APP Bluetooth enabled

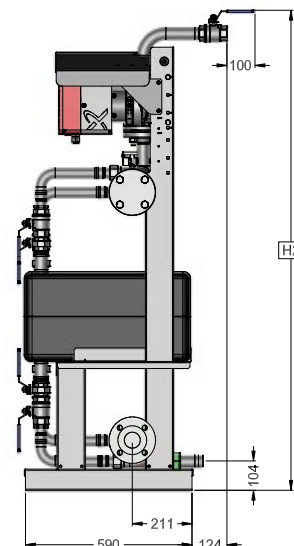
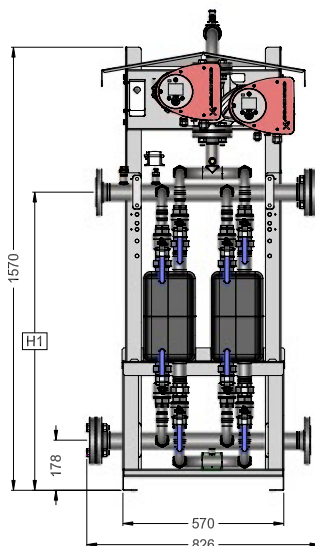

*For full terms and conditions contact Rheem or visit www.rheem.com.au/warranty

MODEL	DIM 'H1'	DIM 'H2'
RD200D701	877	1522
RD400D701	930	1575
RD600D701	993	1638
RD800D701	1056	1701

TECHNICAL DATA

DIMENSIONS AND TECHNICAL DATA TABLE - RHEEM CROSSFLOW						
Model			RD200	RD400	RD600	RD800
Nominal Capacity		kW	200	400	600	800
	Primary Side (non-potable)					
	Inlet Temp	°C	80	80	80	80
	Flow Rate	L/min	48	114	144	186
	Pressure Drop	kPa	24	47	36	36
	Secondary Side (potable)					
	Inlet/Outlet Temp	°C	15/65	15/65	15/65	15/65
Parameters for Nominal Capacity Rating	Flow Rate	L/min	57	115	172	223
	Pressure Drop	kPa	37	47	51	48
Dimensions	H x W x D	mm	1364 x 761 x 700			
Weight		kg	130	138	147	156
Pipe Connections Primary Circuit	BSPF		RP1½			
Pipe Connections Secondary Circuit			50mm Flange Type E			
Max Operating Pressure Primary Circuit	kPa		1400 ²³			
Max Operating Pressure Secondary Circuit	kPa		1400 ²³			
Electrical Supply			230-240V 50/60Hz Hard Wired By Electrician			
Min Circuit Size	Amps		10			

²³ The maximum working pressure of each side of the system will be governed by the lowest operating appliance connected to it. The potable side (secondary side) water pressure must be higher than the non potable side (primary side) pressure.

Cross Flow Delivery Skid Secondary Side Flow Rate for Varying Primary Supply Temperatures and Secondary Side Temperature Rise

200kW						
Primary Temp	90	85	80	75	70	65
Output (kW)	270	215	200	190	160	100
Temp Rise	Secondary Side Flow Rate (L/min)					
65	60	47	44	42	35	
60	65	51	48	45	38	24
55	70	56	52	50	42	26
50	77	62	57	54	46	29
45	86	68	64	61	51	32
40	97	77	72	68	57	36
35	111	88	82	78	66	41

600kW						
Primary Temp	90	85	80	75	70	65
Output (kW)	740	680	600	535	450	300
Temp Rise	Secondary Side Flow Rate (L/min)					
65	163	150	132	118	99	
60	177	162	143	128	108	72
55	193	177	156	139	117	78
50	212	195	172	153	129	86
45	236	217	191	170	143	96
40	265	244	215	192	161	108
35	303	278	246	219	184	123

800kW						
Primary Temp	90	85	80	75	70	65
Output (kW)	940	870	800	695	580	400
Temp Rise	Secondary Side Flow Rate (L/min)					
65	207	192	176	153	128	
60	225	208	191	166	139	96
55	245	227	208	181	151	104
50	269	249	229	199	166	115
45	299	277	255	221	185	127
40	337	312	287	249	208	143
35	385	356	328	285	238	164

400kW						
Primary Temp	90	85	80	75	70	65
Output (kW)	500	450	400	365	300	200
Temp Rise	Secondary Side Flow Rate (L/min)					
65	110	99	88	80	66	
60	119	108	96	87	72	48
55	130	117	104	95	78	52
50	143	129	115	105	86	57
45	159	143	127	116	96	64
40	179	161	143	131	108	72
35	205	184	164	149	123	82

2 x 600kW						
Primary Temp	90	85	80	75	70	65
Output (kW)	1480	1360	1200	1070	900	600
Temp Rise	Secondary Side Flow Rate (L/min)					
65	326	300	265	236	198	
60	354	325	287	256	215	143
55	386	354	313	279	235	156
50	424	390	344	307	258	172
45	471	433	382	341	287	191
40	530	487	430	383	323	215
35	606	557	491	438	369	246

2 x 800kW						
Primary Temp	90	85	80	75	70	65
Output (kW)	1880	1740	1600	1390	1160	800
Temp Rise	Secondary Side Flow Rate (L/min)					
65	415	384	353	307	256	
60	449	416	382	332	277	191
55	490	453	417	362	302	208
50	539	499	459	398	333	229
45	599	554	510	443	369	255
40	674	624	573	498	416	287
35	770	713	655	569	475	328

TECHNICAL DATA

Rheem Crossflow Maximum Output (Tin¹⁵°C-Tin⁶⁵°C) vs. Primary supply temp

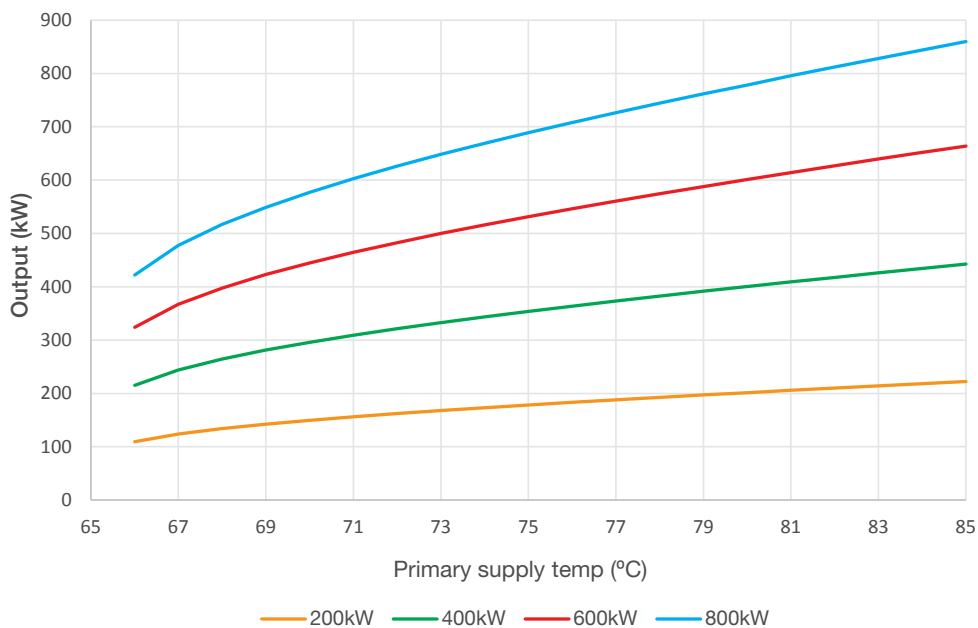

Rheem Crossflow Secondary Side Pressure Drop vs. Flow Rate

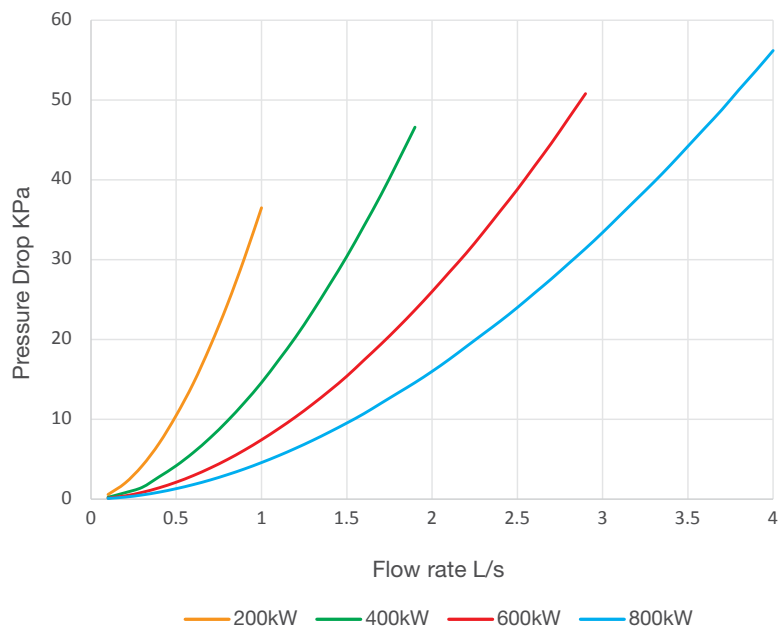

BRAZED PLATE HEAT EXCHANGER

SUITED TO CO-GEN AND TRI-GEN PLANTS, PROCESS HEATING, AND PRESSURE REDUCTION STATIONS



STAINLESS STEEL



EASY TO MAINTAIN



WASTE HEAT RECOVERY



MINIMUM PRESSURE DROP

The most versatile heat exchanger available.

IDEAL FOR CUSTOM ENGINEERING DESIGNS

316L stainless steel, single wall, brazed plate heat exchangers can be bolted together when more capacity is needed. Suits specialist applications, where high temperature and high pressure are needed.

EASY TO INSPECT AND MAINTAIN

Unlike other products that use internal coils, the external heat exchanger is easily isolated for repairs and maintenance.

MINIMAL PRESSURE LOSS ENERGY TRANSFER





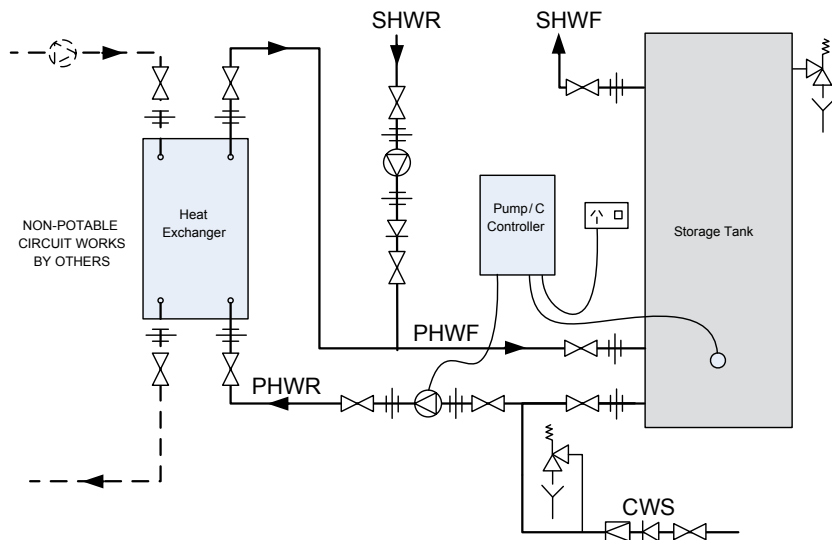

Parallel brazed plate construction means increased flow without the pressure drop and high heat transfer efficiency in a compact package.

Contact Rheem for assistance confirming the rated capacity of heat exchangers taking into consideration site specific requirements.



Legend

CWS: cold water supply
 PHWR: primary hot water return
 PHWF: primary hot water flow
 SHWS: secondary hot water supply
 SHWR: secondary hot water return

- | | | | |
|---|-----------------|---|-------------------------|
|  | ECV |  | Non return valve |
|  | TPR valve |  | Pressure limiting valve |
|  | Tundish |  | Union |
|  | Isolation valve |  | Circulator or pump |



*For full terms and conditions contact Rheem or visit www.rheem.com.au/warranty

TECHNICAL DATA

DIMENSIONS AND TECHNICAL DATA TABLE - RHEEM HEAT EXCHANGER									
Part Number				0191750	0191751	0191752	0191753	0191754	
Nominal Rating				kW	50	100	150	200	250
Parameters for Nominal Rating	Non Potable Side	Inlet/Outlet Temp	°C	80/60	80/60	80/60	80/60	80/60	
		Flow Rate	L/sec	0.61	1.22	1.83	2.44	3.05	
		Pressure Drop	kPa	2.65	3.74	5.00	6.98	9.83	
	Potable Side	Inlet/Outlet Temp	°C	45/65	45/65	45/65	45/65	45/65	
		Flow Rate	L/sec	0.61	1.21	1.82	2.43	3.03	
		Pressure Drop	kPa	2.39	3.59	4.91	6.91	9.79	
Dimensions		Depth (D)	mm	104	160	221	277	333	
Weight			kg	6	9	12	15	18	
Operating Pressure			kPa	3000 ¹					
Electrical Supply (Temperature Controller)				230-240V 50/60Hz Hard wired by Electrician					

¹ The maximum working pressure of each side of the system will be governed by the lowest operating appliance connected to it. The potable side (secondary side) water pressure must be higher than the non potable side (primary side) pressure.

POTABLE SIDE PUMP AND PIPE SIZING					
Heat Exchanger Model	Qty In Parallel	Output (kW)	Design Flow Rate	Minimum Potable Primary F & R Pipe Size (mm)	Pump Model / Speed Setting
0191750	1	50	0.61	32	UPS20-60N / 3
0191750	2	100	1.22	40	UPS32-80N / 3
0191751	1	100	1.21	40	UPS32-80N / 3
0191751	2	200	2.42	50	UPS40-60/2FB / 2
0191752	1	150	1.82	50	UPS32-80N / 3
0191752	2	300	3.64	65	UPS40-60/2FB / 3
0191753	1	200	2.43	50	UPS40-60/2FB / 3
0191753	2	400	4.86	80	UPS50-120FB / 1
0191754	1	250	3.03	65	UPS40-60/2FB / 3
0191754	2	500	6.06	80	UPS50-120FB / 3

NOTE: Pipe sizing, pump selection and installation of the NON-POTABLE circuit is not covered by Rheem. Pipe and pump sizing is for potable water side only between the heat exchanger and storage tank/s and is based on 25m TOTAL pipe run and 20 x 90° bends @1.2m/s. If the piping is beyond this scope, please contact Rheem for assistance.

