

ITEM	QTY	DESCRIPTION
1	1	CONNECTOR MALE 4WAY LTW12P-04BMMA-SL8001 (MANUFACTURER: AMPHENOL LTW)
2	1	CONNECTOR JST SMP-02V-BC, SCOKET CONNECTOR SHF-001T-0.8BS

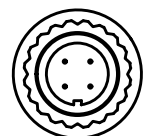

MALE PIN  
LTW CONNECTOR

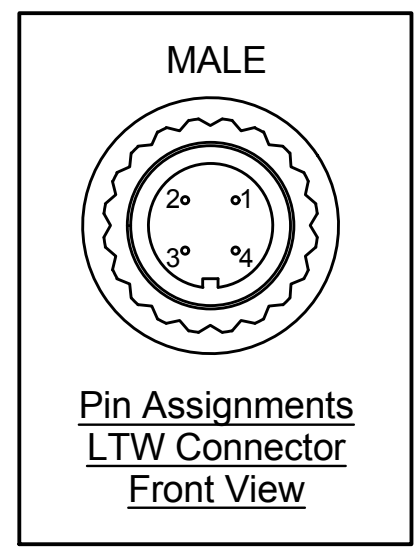
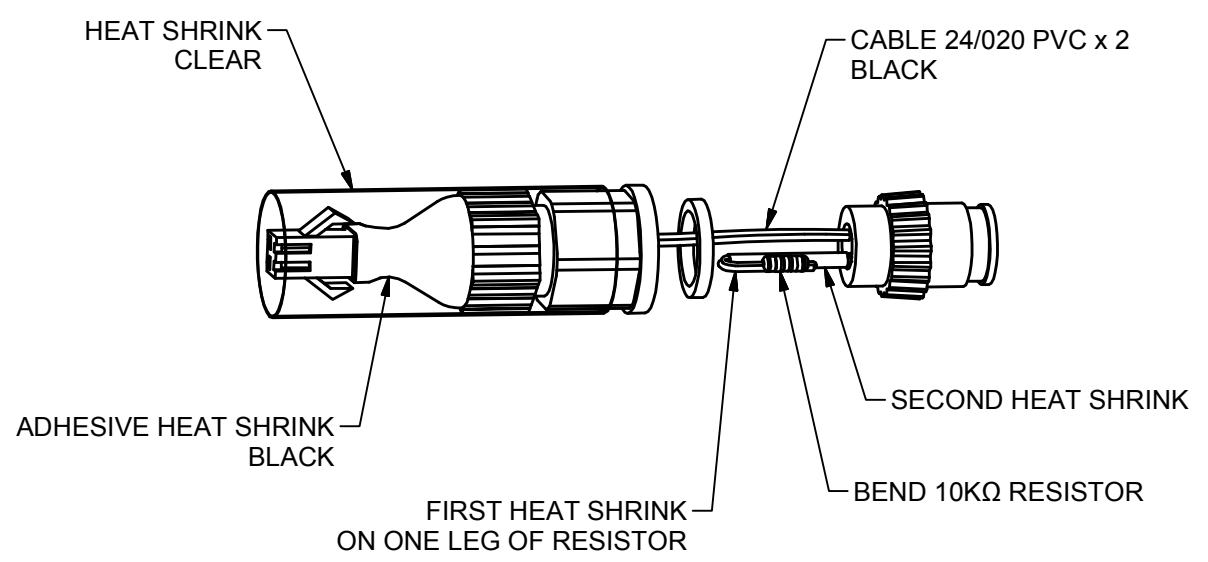
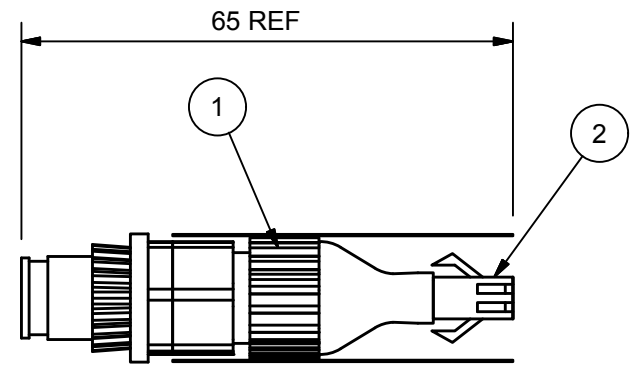

Pin Assignments  
LTW Connector  
Front View

SOLDERING DETAIL	
CONNECTOR PIN	PIN OUT
1	JST CONNECTOR
2	RESISTOR
3	RESISTOR
4	JST CONNECTOR

**NOTES:**

- PART 057340 TO BE PACKED IN A PRESS SEALED BAG 150 x 230.
- LABEL (100 x 50) WITH WORDING "ONLY USE WHEN CONNECTING 2 WAY CABLE HOT SENSOR LEAD TO SOLAR CONTROLLER P/N 052212 OR 052219" TO BE AFFIXED ON LOWER PORTION OF THE BAG.
- SERVICE LABEL (100 x 73) TO BE PRINTED FROM SAP BY RHEEM SPARE PARTS DEPARTMENT WHEN THE PART ARRIVES TO SPARES WAREHOUSE AT RYDALMERE.

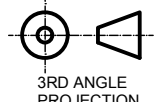
AD	WH14878	New Drawing Issued			M.H.	Y.Z.	8/16	
REV	ECO No.	DETAILS				BY	CHD	DATE
		This drawing and the information contained herein is the sole property of Rheem Australia Pty. Ltd, is strictly confidential and may not be used or disclosed without the written consent of Rheem Australia Pty. Ltd.				DISTRIBUTION:		
		SHARP CORNERS TO BE BROKEN, UNLESS STATED. DO NOT SCALE				R		
Dwn	Ch'd	App'd by	UNLESS OTHERWISE STATED ALL DIMENSIONS IN mm.		RHEEM AUSTRALIA PTY. LTD			
M.H.			TOLERANCES		DESCRIPTION:			
8/16			GENERAL: ±		CONNECTOR CONVERSION			
SCALE	SIZE	HOLE SIZE: ±		SOLAR LOLINE COMM				
1:1	A3	ANGULAR: ±		Sheet 1 / 1		Rev AD		
				DWG.No.		057340		