

Rheem Hiline 52D

52D180

1 - 2

PEOPLE

Outdoor

INSTALLATION



Features & Benefits

- Energy efficient
- Booster – choice of electric element or 6-Star continuous flow gas
- Vitreous enamel lined cylinder
- Eligible for STCs⁵
- 5 year cylinder warranty¹

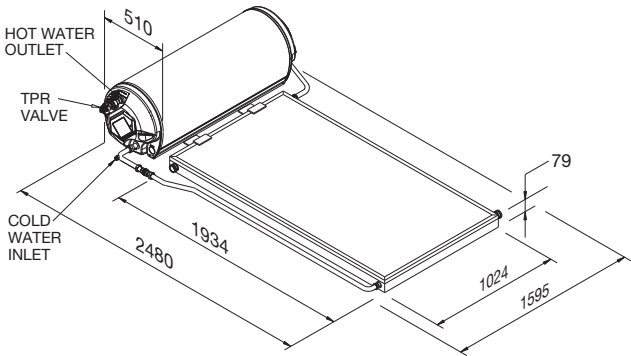

MODEL	52D180
Storage Capacity (L)	180
Solar Collectors	1 NPT200
Booster Type	Electric or Gas
Weight Empty (kg) - Tank	60
Hot Water Connection	Rp ³ / ₄
Cold Water Connection	G ¹ / ₂ B



Scan code for details & installation instructions

