



NEW DESIGN

RHEEM 80L ELECTRIC WATER HEATER

DELIVERS 91 LITRES OF HOT WATER



THE 80 LITRE WITH MORE
delivers 91L of hot water suitable for
installation in small spaces

SMALL DIAMETER
only 460mm making installation simple

DUAL HANDED
for easier installation



COMES ON STEADY, HOT AND STRONG

INSTALL A



NEW Rheem 80L

ELECTRIC STORAGE WATER HEATER

The Rheem dual handed 80 Litre electric water heater has a space saving design that's ideal for installations in tight spaces.

KEY FEATURES

Dual handed fittings

make it more convenient for installation. No matter which way the unit is rotated all the fittings are accessible, making it easier to install into those tight spaces

12 year cylinder warranty¹

Full technical support through Rheem's National Service Network



Rheem Electric		80L
Model		481080
Hot Water Delivery	Litres	91
Warranty	years	12
Storage Capacity	Litres	96
kW Rating	1.8	✓
	3.6	✓
Relief Valve Setting	kPa	1400
Expansion Control Valve (kPa)	kPa	1200
Max Water Supply Pressure:		
with ECV (kPa)	kPa	960
without ECV (kPa)	kPa	1120
Inlet/Outlet Connections	Rp	³ / ₄
Dimensions		
A	mm	945
B	mm	460
C	mm	496
Weight (packaged)	kg	36

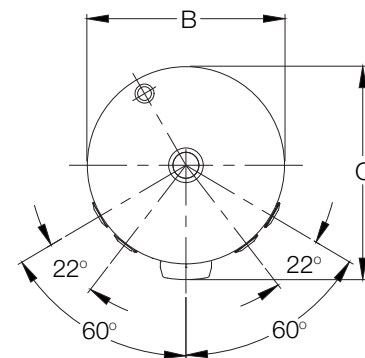
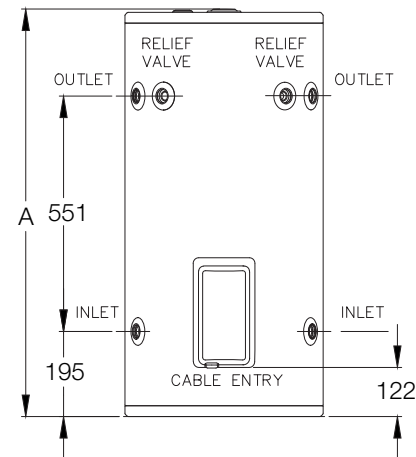

¹ Warranty: 12 Years on Cylinder, 1 Years Labour on Cylinder, 1 Year Parts & Labour warranty on all other components for Domestic (non-Commercial) installations. Conditions apply. See the Rheem warranty set out in the Owner's Guide & Installation Instructions or view at www.rheem.com.au/warranty

² Rated hot water delivery is 91L in accordance with AS/NZS4692.1.

Materials and data are subject to change without notice.

Rheem Australia Pty Ltd.

1 Alan Street, Rydalmere, New South Wales 2116, Australia
PO Box 7508 Silverwater NSW 2128, Australia.

www.rheem.com.au

® Registered Trademark of Rheem Australia Pty Ltd.

™ Trademark of SAI Global.

