

Installation Instructions



Air Sourced Integrated Heat Pump Module MPi Series

*This water heater must be installed and serviced by a qualified person.
Please leave this guide with the householder.*

An electronic copy of these Installation Instructions can be downloaded from
rheem.com.au.

PATENTS

This water heater may be protected by one or more patents or registered designs
in the name of Rheem Australia Pty Ltd.

TRADE MARKS

® Registered trademark of Rheem Australia Pty Ltd.
™ Trademark of Rheem Australia Pty Ltd.

Note: Every care has been taken to ensure accuracy in preparation of this publication.
No liability can be accepted for any consequences,
which may arise as a result of its application.

CONTENTS

HOUSEHOLDER – This installation instruction booklet is intended for the installer but you may find it of interest.

Installation	4
Heat Pump And Tank Assembly	14
Connections – Electrical	29
Commissioning	31
Water Supplies	37
Warranty Note	39

INSTALLATION

INSTALLATION NOTES

These instructions cover only the installation of the heat pump module onto the storage tank and the connections made between the heat pump module and storage tank. Refer to the Owner's Guide and Installation Instructions supplied with the storage tank for further information including:

- where and how to locate the heat pump water heater
- how to connect the heat pump water heater to the electricity supply and to the plumbing system
- how to operate the heat pump water heater
- what to do if something goes wrong.

Installation Standards

The water heater must be installed:

- by a qualified person,
- in accordance with the installation instructions,
- in compliance with the Plumbing Standard AS/NZS 3500.4,
 - This water heater is designed for outdoor installation only.
 - Refer to **dimensions diagram** on page 10 or 11 for clearance requirements to provide adequate ventilation for the heat pump module.
- in compliance with the Wiring Rules AS/NZS 3000,
 - Electrical connections between the heat pump module and storage tank are made using mating connectors fitted to these components.
- in compliance with all local codes and regulatory authority requirements.
- in New Zealand, the installation must also conform to Clauses G12 and H1 of the New Zealand Building Code.

SAFETY AND WARNINGS

- This water heater is only intended to be operated by persons who have the experience or the knowledge and the capabilities to do so.
- This water heater is not intended to be operated by persons with reduced physical, sensory or mental capabilities i.e. the infirm, or by children. Children should be supervised to ensure they do not interfere with the water heater.

- This water heater uses 220 V - 240 V a.c. electrical power for operation of the control systems and the electrically operated components. The removal of the access cover(s) will expose 220 V - 240 V a.c. wiring. They must only be removed by a qualified person.
- The heat pump module will operate until a water temperature of 60°C is reached. If the ambient air temperature is outside of the heat pump's operating range and heating of water is required, a booster electric heating unit will heat the water temperature to 70°C.
- For continued safety of this water heater it must be installed, operated and maintained in accordance with the Owner's Guide and Installation Instructions supplied with the storage tank.
- Servicing of the water heater must only be carried out by qualified personnel. Phone Rheem Service or their nearest Accredited Service Agent / Centre.
- Ensure the air flow, air inlet louvres and outlet grille are not obstructed in any way at any time.
- Do not modify this water heater.

MAINS WATER SUPPLY

Where the mains water supply pressure exceeds that shown in the table below, an approved pressure limiting valve is required. Refer to the Owner's Guide and Installation Instructions supplied with the storage tank for the position of the pressure limiting valve.

Model	325
Temperature pressure relief valve setting	1000 kPa
Expansion control valve setting *	850 kPa
Maximum mains supply pressure	
With expansion control valve	680 kPa
Without expansion control valve	800 kPa
Minimum mains supply pressure	200 kPa

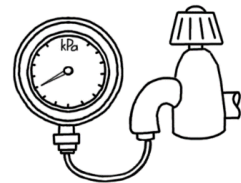

* Expansion control valve not supplied with the water heater.

A minimum water supply pressure of 200 kPa is required to enable the heat pump circulator and heat pump system to operate effectively.

TANK WATER SUPPLY

If the water heater is supplied with water from a tank supply and a minimum water supply pressure of 200 kPa at the water heater cannot be achieved, then a pressure pump system must be installed to allow the heat pump circulator to operate and avoid air locks in the circuit. Care must be taken to avoid air locks. The cold water line from the supply tank should be adequately sized and fitted with a full flow gate valve or ball valve.

WATER HEATER APPLICATION

This water heater is designed for use in a single family domestic dwelling for the purpose of heating potable water. Its use in an application other than this may shorten its life.

If this water heater is to be used where an uninterrupted hot water supply is necessary for the application or business, then there should be back-up redundancy within the hot water system design. This should ensure the continuity of hot water supply in the event that this water heater was to become inoperable for any reason. We recommend you provide advice to the system owner about their needs and building back-up redundancy into the hot water supply system.

The 551325 or 554325 model water heater is recommended for connection to either a 24 hour continuous tariff or an extended off-peak (minimum 16 hours per day – replacement model and climate dependant) power supply. If replacing an electric water heater greater than 250 litres, heat pump connection to a 24 hour continuous tariff is recommended.

FREEZE PROTECTION

The water heater has a freeze protection system. The freeze protection system will protect the water heater from damage, by preventing ice forming in the waterways of the water heater, in the event of freezing conditions occurring.

If the ambient air temperature falls below 1°C and the heat pump is not operating, the system will operate the circulator periodically. During this freeze protection cycle, the circulator will operate for thirty (30) seconds and then rest for fifteen (15) minutes, before the cycle is recommenced. Water is circulated from the storage tank through the heat pump circuit, to prevent freezing in the connecting pipe work and heat pump module. The green LED will flash a series of four (4) flashes whilst the circulator is operating.

 **Warning:** In areas where the ambient air temperature may fall below 1°C, power must be available to the water heater at all times to prevent freezing in the heat pump circuit.

The water heater has NO WARRANTY for freeze damage if power is unavailable at the water heater.

TO TURN OFF THE WATER HEATER

If it is necessary to turn off the water heater on completion of the installation, such as on a building site or where the premises are vacant, then:

- Switch off the electrical supply at the water heater isolating switch on the switchboard and at the isolating switch at the water heater.
- Close the cold water isolation valve at the inlet to the water heater.

Notes

- The freeze protection system will be rendered inoperable if electrical power is not available at the water heater.
- Damage caused by freezing due to the unavailability of power at the water heater is not covered by the Rheem warranty.

Refer to “**Warranty Note**” on page 39.

- If the power has been switched off to the water heater and there is a risk of freezing, then it is necessary to drain the water heater.

Refer to “Draining the Water Heater” in the Owner’s Guide and Installation Instructions supplied with the heat pump storage tank.

ENVIRONMENT

At the end of the service life of the heat pump water heater and prior to the water heater being disposed of, a person qualified to work with refrigerants must recover the refrigerant from within the sealed system. The refrigerant must not be vented to atmosphere. Phone Rheem Service or their nearest Accredited Service Agent / Centre to arrange for an inspection.

VICTORIAN CUSTOMERS

Notice to Victorian Customers from the Victorian Plumbing Industry Commission. This water heater must be installed by a licensed person as required by the Victorian Building Act 1993.

Only a licensed person will give you a Compliance Certificate, showing that the work complies with all the relevant Standards. Only a licensed person will have insurance protecting their workmanship for 6 years. Make sure you use a licensed person to install this water heater and ask for your Compliance Certificate.

STORAGE TANK AND HEAT PUMP MODULE

The heat pump water heater is made of two main components, the storage tank and the heat pump module. For transport and handling (weight) purposes both items are shipped separately and designed to be assembled at the installation site. The water heater must not be operated until both components are assembled. Refer to “[Heat Pump and Tank Assembly](#)” on page 14.

Care must be taken during transportation and handling. Do not lay the heat pump module down and do not tilt the heat pump module or the heat pump and storage tank assembly more than 30° from the vertical. This will displace the compressor lubricating oil. If the heat pump module or heat pump and storage tank assembly has been tilted more than 30° from the vertical during handling, it will need one hour to drain back before the power to the water heater can be switched on, otherwise damage to the compressor may result.

All packaging materials must be removed from the heat pump module prior to its installation. This includes the removal of the cardboard base of the carton from the underside of the module. Take care when handling the heat pump module. The jacket of the heat pump module needs to be handled gently so as not to cause damage.

A clearance of 300 mm is required perpendicular from both the front air inlet louvres and the outlet grille to any wall or obstruction. Refer to the dimensions diagram on page 10 or 11.

The heat pump module must be installed on and fully supported by a stable base.

The water heater must not be installed in an area with a corrosive atmosphere where chemicals are stored or where aerosol propellants are released. Remember the air may be safe to breathe, but the chemicals may attack the materials used in the heat pump system.

⚠ Warning: This heat pump module is designed to be installed with a purpose built water heater storage tank and may not be used for any other purpose.

CONDENSATE DRAIN

A drain line should be fitted to the heat pump module’s condensate drain to carry the discharge clear of the water heater. The drain line can be extended using 12 mm rigid poly hose or conduit. The pipe work from the condensate drain should be as short as possible and fall all the way from the water heater with no restrictions. It should have no more than three right angle bends in it. The outlet of the drain line must be in such a position that flow out of the pipe can be easily seen - but arranged so water discharge will not cause damage or nuisance.

The condensate drain line must not be connected to the relief valves drain lines but may discharge at the same point.

DIMENSIONS AND TECHNICAL DATA

System number			551325	554325
Tank model number			T55132507	T55432507
Storage tank capacity		litres	325	325
Boost capacity	3.6 kW*	litres	180	180
Weight tank	cartoned	kg	96	98
Weight heat pump	cartoned	kg	42	42
Weight system	cartoned	kg	138	140
Weight system	full	kg	455	455

Heat pump module model number			182550
Maximum rated power input		watts	3600
Rated heat pump power input		watts	800
Booster element ratings		kW	3.6
Refrigerant type			R134a
Refrigerant circuit pressure		kPa	3000

* The boost capacity of a 3.6 kW low watts density heating unit if used is 100 litres.

Technical data is subject to change.

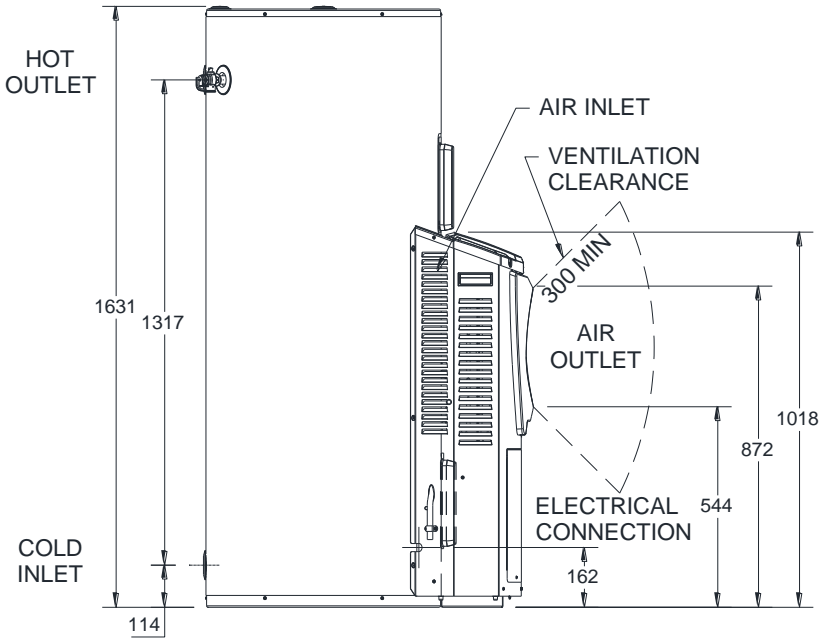
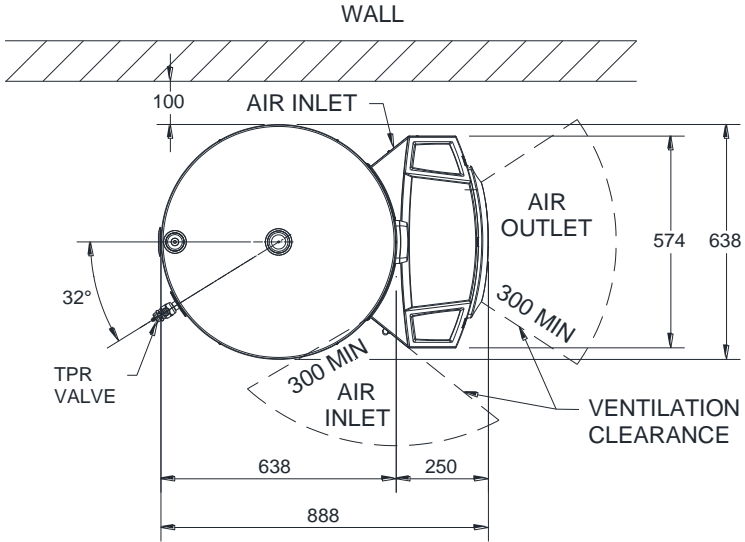

Rheemglas 551 Series

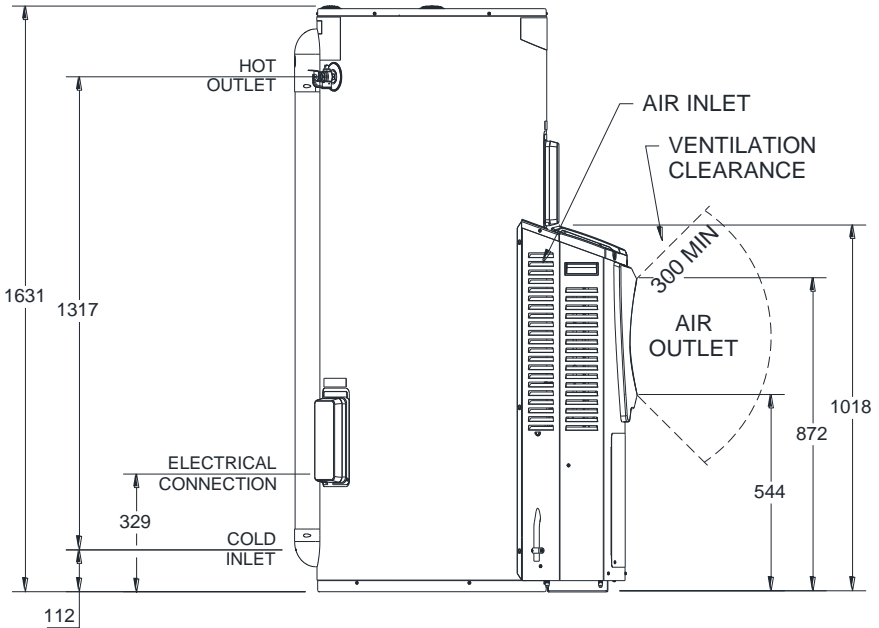
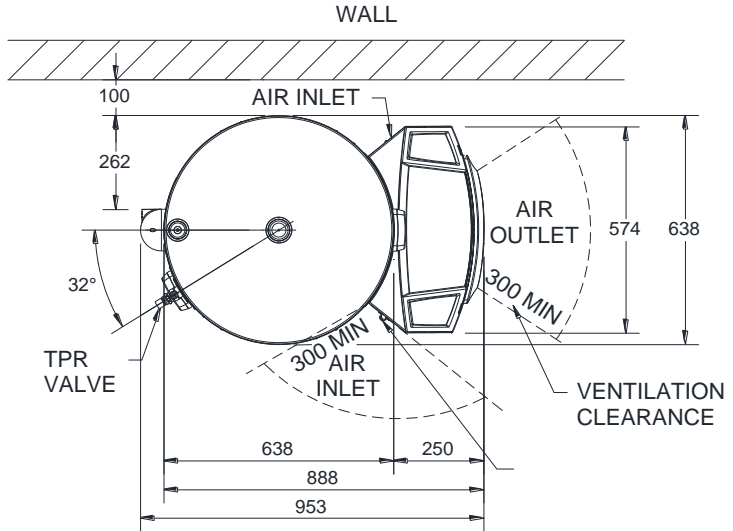

RheemPlus 554 Series

TYPICAL INSTALLATION – OUTDOOR LOCATION

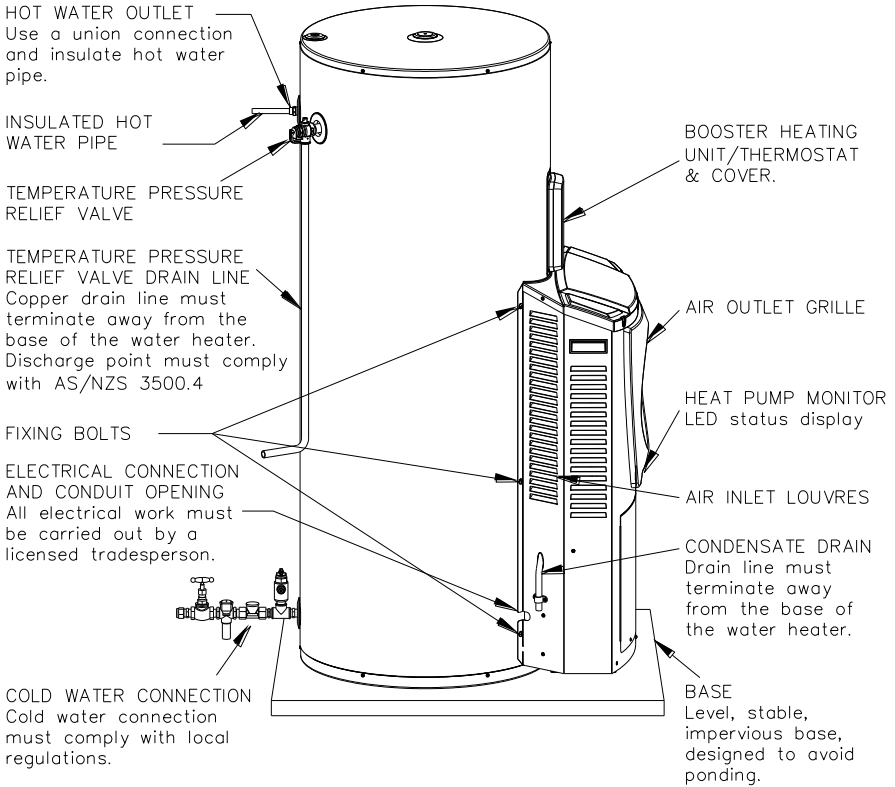

Rheemglas 551 Series Shown

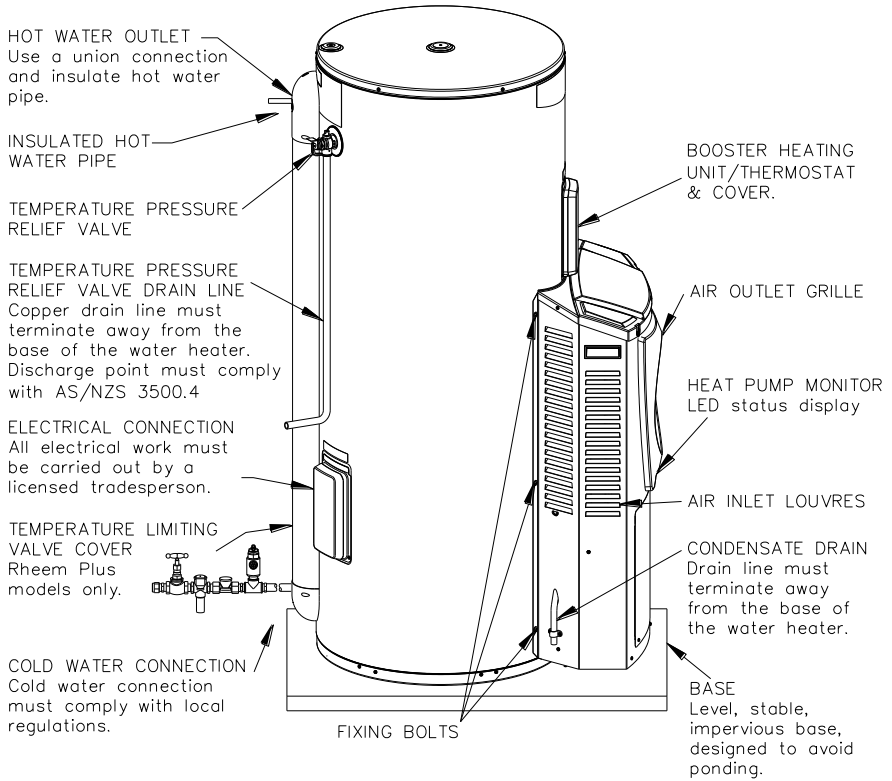

Rheemglas 554 Series Shown

HEAT PUMP AND TANK ASSEMBLY

STORAGE TANK AND HEAT PUMP MODULE

The heat pump water heater is made of two main components, the storage tank and the heat pump module. For transport and handling (weight) purposes both items are shipped separately and designed to be assembled at the installation site. The water heater must not be operated until both components are assembled.

The water heater is to be installed at ground or floor level and must stand vertically upright on a stable base, as acceptable to local authorities, of a minimum 900 mm wide x 650 mm deep. The heat pump module must be fully supported by the stable base.

HEAT PUMP MODULE

The heat pump module is shipped in a box containing two hand holes to facilitate easy handling and lifting. The heat pump module is to be mounted against the side of the storage tank.

CAUTION: The heat pump module weighs approximately 42 kg when cartoned. Use the hand holes provided in the sides of the packaging. Good lifting practice should be followed.

There are two flexible hoses provided inside the heat pump module. The flexible hoses are to be withdrawn from the module and fixed to the two water fittings on the heat pump storage tank, during the assembly procedure.

There are two connection points located on the underside of the control box in the heat pump module to which the power cable and tank sensor cable from the heat pump storage tank are connected, during the assembly procedure.

STORAGE TANK

The storage tank is designed to receive the heat pump module. There are two water fittings located at the side of the storage tank to which flexible hoses from the heat pump module are connected, during the assembly procedure.

A power cable is housed behind the lower cover and a tank sensor cable is located adjacent to and above to the lower cover of the storage tank. The power cable is to be withdrawn from behind the front cover and the tank sensor cable unfurled and both connected to the control box in the heat pump module during the assembly procedure.

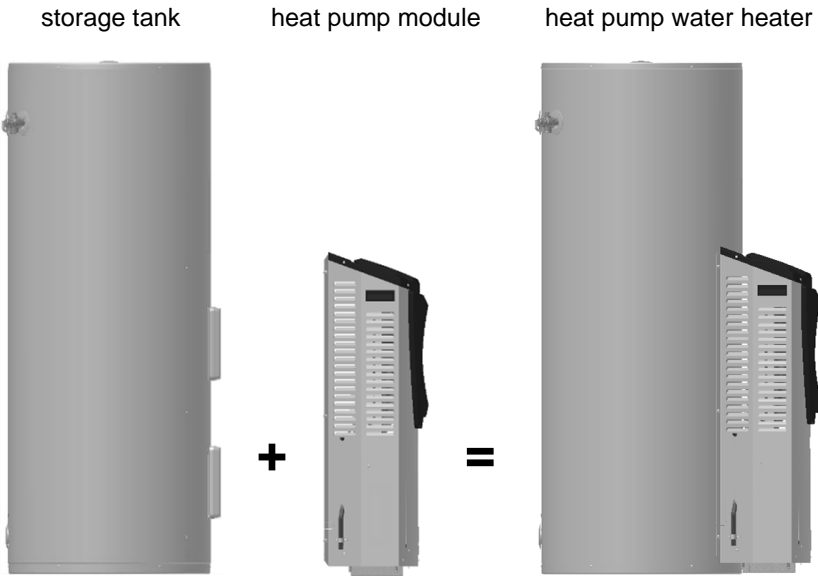
**KIT**

There is a kit (PN 299276) supplied with the heat pump module.

The components supplied in the kit and required for the installation are:

299276	Kit Installation Heat Pump Module Integrated	Qty
122189	Installation instructions heat pump module integrated	1
052158	Saddle clamp 20 mm Clipsal 261/20	1
080021	Screw phillips pan head No. 8 x 13 zinc plated black	2
080156	Screw pack of 3 M6 x 12 HD bolts	2
080203	Stud M6 x 25 zinc plate	3
080204	Nut hex whizzlock M6	3
104767	Cover fan shroud	1
080191	Screw hilo 13-16 x 20 pan head combination zinc plated	1
104766	Plug plastic 13 mm black	1

ASSEMBLY PROCEDURE

⚠ Warning: The heat pump must be assembled, plumbed and filled with water prior to power being connected and switched on.

The following procedure should be followed to properly place the heat pump module in position and connect to the storage tank:

1. **Heat Pump Storage Tank:** Remove all packaging including the carton base from the heat pump storage tank and position in its intended location, supported by a stable base.

The water connections may be on either the left or right hand side and should be parallel to the wall.

The storage tank must be positioned at least 100 mm from the wall. If a minimum clearance of 100 mm is not allowed for, the heat pump module will not be able to be completely connected to the storage tank.

The storage tank must also be positioned such that when the heat pump module is in position, there is a clearance of at least 300 mm perpendicular from both the front air inlet louvres and the outlet grille to any wall or obstruction.

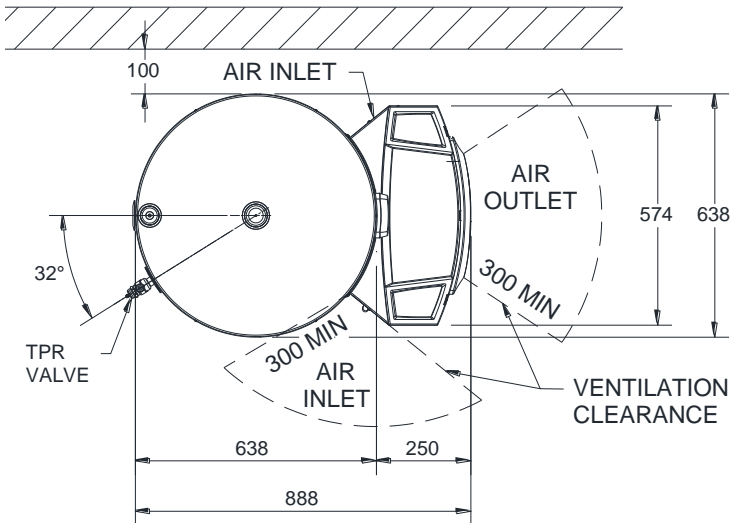

Step 1
position storage tank at least 100 mm from the wall
and allow for at least 300 mm ventilation clearance
551 series shown above

2. **Lower Front Cover:** Remove the two screws securing the lower front cover to the storage tank.
 - Remove the lower front cover from the storage tank.



Step 2
remove screws
from lower front cover



Step 3
withdraw the power cable

3. **Power Cable:** Withdraw the power cable, housed behind the lower front cover, from the opening.

4. **Mains Power Connection – 551 Series:** Connect the mains power supply wiring to the terminal block and earth connection inside of the lower front cover.
 - Secure the conduit to the side of the storage tank with the saddle clamp and screws provided.

The saddle clamp must be positioned over the pilot holes provided, otherwise the conduit will interfere with the heat pump module installation.

Refer to “Connections – Electrical” on page 29.

Note: The power supply to the water heater must not be switched on until the installation is complete, the water heater is filled with water and a satisfactory megger reading is obtained.



Step 4
Connect wiring and secure conduit with saddle clamp

5. **Lower Front Cover:** Refit the lower front cover.



Step 5
refit lower front cover



Step 6
remove tape from tank sensor cable

6. **Tank Sensor Cable:** Remove tape from tank sensor cable and unfurl.
7. **Heat Pump Module:** Remove all packaging including the carton base from the heat pump module and position in its intended location at the storage tank.

CAUTION: The heat pump module weighs approximately 42 kg when cartoned. Use the hand holes provided in the sides of the packaging. Good lifting practice should be followed.

8. **Fan Cover Shroud:** Retrieve the fan cover shroud, 20 mm screw and black plastic plug from the kit bag.
- Remove the screw located immediately above the monitor label on the front of the heat pump module and discard.
 - Position the fan cover shroud over the fan cowl and slide the recessed edge of the shroud under the lip of the heat pump module top. It will slide under the top without having to remove any screws.
 - Align the mounting hole at the bottom of the shroud with the screw hole in the heat pump module located immediately above the monitor label.
 - Secure the fan cover shroud to the heat pump module with the 20 mm screw provided.
 - Insert the black plug provided into the recess to cover the head of the screw.

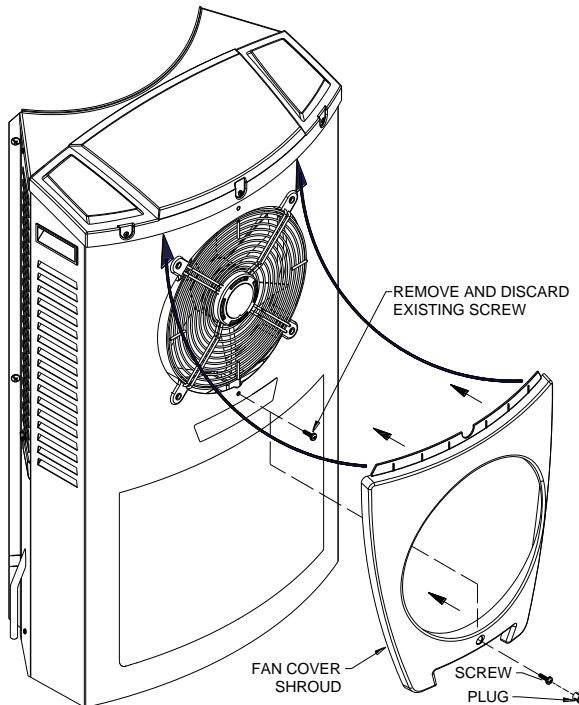

Step 8
fit the fan cover shroud to the heat pump module

9. **Heat Pump Module Cover:** Remove the two screws securing the front cover to the heat pump module.
 - Remove the front cover from the heat pump module.



Step 9 and 11
remove front cover from heat pump module
and feed through cables

10. **Position Heat Pump Module:** Position the edge of the heat pump module which is closest to the wall against the storage tank so the screw holes in the module are adjacent to the nutserts in the storage tank.
11. **Power Cable and Tank Sensor Cable:** Feed the power cable from the lower front cover and tank sensor cable through the heat pump module so they protrude out of the front of the module.
12. **Flexible Braided Hoses:** Retrieve the loose ends of the two flexible braided hoses from within the heat pump module, and withdraw through the rear of the heat pump module.

13. **Cold Hose Connection:** Attach the flexible braided hose, marked with a blue stripe through the braid and attached to the bottom of the heat exchanger, to the ball valve fitting in the bottom connection on the storage tank and marked “TO HEAT PUMP”.

- Tighten the swivel nut on the hose using a 24 mm spanner.
Tape or sealant is not required.
- Position the hose such that when the heat pump module is moved and secured to the tank, it does not kink.
- **Ball valve:** Ensure the ball valve located in the connection fitting is in the open position. In the open position, the slot is in line with the hose.

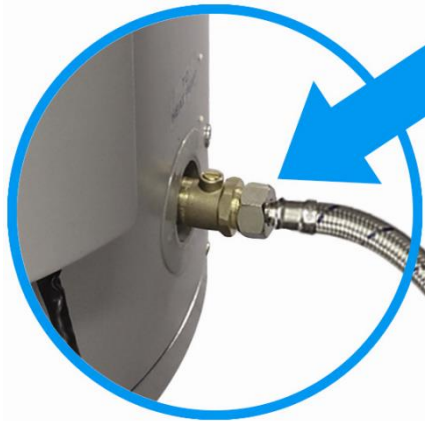

TO
HEATPUMP

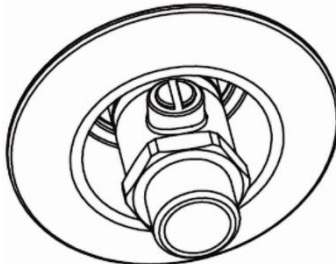

Step 13
attach flexible hose with blue stripe to inlet and ball valve in open position

14. **Hot Hose Connection:** Attach the flexible braided hose, marked with a red stripe through the braid and attached to the top of the circulator, to the non-return valve fitting in the upper connection marked “OUTLET” in red on the storage tank.
- Tighten the swivel nut on the hose using a 24 mm spanner.
- Tape or sealant is not required.
- Position the hose such that when the heat pump module is moved and secured to the tank, it does not kink.



Step 14
attach flexible hose with red stripe to outlet

15. **Check Hoses:** Check to ensure the flexible hoses are not kinked.

16. **Cable Tab – 551 Series:** Remove the tab on the side of the electrical entry to the heat pump module to accommodate the electrical conduit.

Pliers or tin snips may be required to remove the tab.



Step 16

remove the tab on the side of the electrical entry to the heat pump module

17. **Studs:** Retrieve the three (3) studs from the kit and screw into the three (3) threaded inserts on the side of the tank closest to the wall.

These studs will assist in aligning the heat pump module for connection to the storage tank.



Step 17

screw in studs into threaded inserts

18. **Position Heat Pump Module:** Position the heat pump module against the tank.
- Engage the tab at the bottom of the heat pump module, on the wall side of the module, into the slot in the tank.
 - Align the holes in the side of the heat pump module over the three studs.
19. **Flange Nuts:** Screw the three flange nuts onto the studs to connect the wall side of the heat pump module to the storage tank.

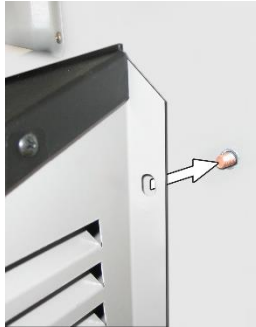

Steps 18 and 19
align heat pump module over studs and screw on flange nuts

20. **Tab:** Engage the tab at the bottom of the heat pump module, on the front side of the module, into the slot in the tank.
21. **Fixing Bolts:** Screw in the three fixing bolts to connect the front side of the heat pump module to the storage tank.



Step 21
screw in fixing bolts to connect heat pump module to storage tank

22. **Tank Sensor Cable Connection:** Insert the tank sensor cable plug to the connector on the underside of the control box.

The plug is polarised and can only be inserted one way.

- Ensure the plug fully engages the locking feature on the connector.

23. **Power Cable Connection:** Insert the four pin power cable plug to the connector on the underside of the control box.

The plug is polarised and can only be inserted one way.

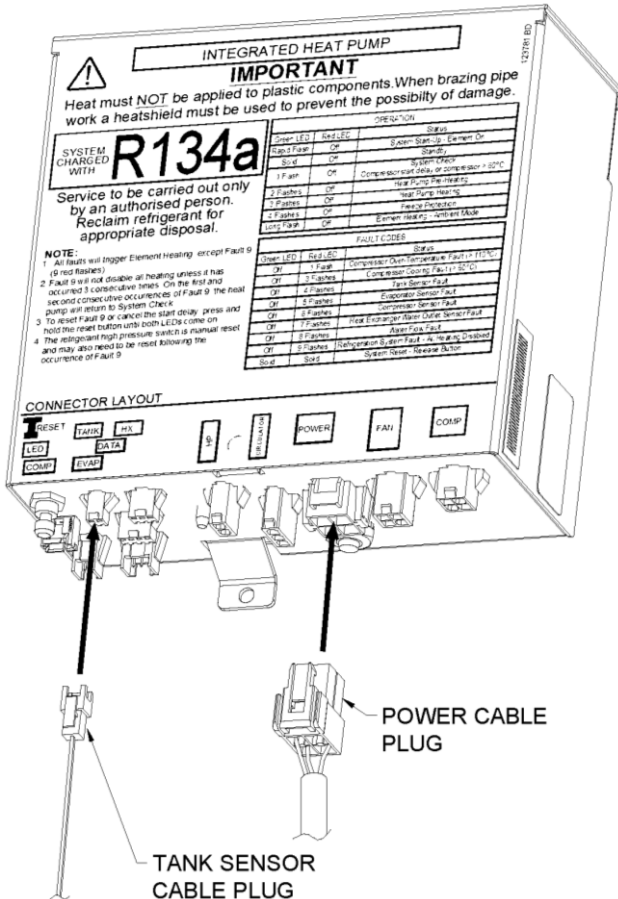

Steps 22 and 23
connect power cable and tank sensor cable

24. **Positioning of Water Heater:** Complete final positioning of the water heater.
- Ensure the heat pump module is firmly seated on the level slab or solid base.
25. **Water Connections:** Connect the cold water supply and the hot water pipe work to the water heater.
- Connect the temperature pressure relief valve and its drain line.
- Refer to “**Connections – Plumbing**” in the Owner’s Guide and Installation Instructions supplied with the storage tank.
26. **Water Supply:** Turn on the cold water supply and fill the water heater.
- Check the pipe work and the connection points for the flexible braided hoses for leaks
- Refer to “**To Fill And Turn On The Water Heater**” on page 31, however the electrical supply should not be turned on at this stage.
27. **Heat Pump Module Cover:** Replace the heat pump module cover and re-fit the two screws.



Step 27
replace heat pump module front cover

28. **Electrical Cover – 554 Series:** Remove the two screws securing the electrical cover, adjacent to the temperature limiting valve cover, to the storage tank.

- Remove the electrical cover from the storage tank.



Step 28
remove screws from electrical cover

29. **Mains Power Connection – 554 Series:** Connect the mains power supply wiring to the terminal block and earth connection inside of the electrical cover.

- Secure the conduit to the side of the storage tank with the saddle clamp and screws provided.

Refer to “[Connections – Electrical](#)” on page 29.

Note: The power supply to the water heater must not be switched on until the installation is complete, the water heater is filled with water and a satisfactory megger reading is obtained.

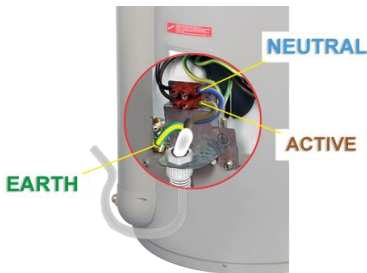

Step 29
connect wiring to terminal block



Step 30
refit electrical front cover

30. **Electrical Cover – 554 Series:** Refit the electrical cover.

31. **Commissioning:** Refer to “[Commissioning](#)” in the Owner’s Guide and Installation Instructions supplied with the storage tank.

CONNECTIONS – ELECTRICAL

The power supply to the water heater must not be switched on until the water heater is filled with water and a satisfactory megger reading is obtained.

MEGGER READING

When a megger test is conducted on this water heater, then the following should be noted.

⚠ Warning: This water heater contains electronic equipment and 500 V insulation tests must only be conducted between active and earth and between neutral and earth. An active to neutral test WILL damage the electronics.

An insulation test result of between 100 K Ω and 660 K Ω for this water heater is normal.

AS/NZS 3000 permits an insulation test result less than 1 M Ω where the appliance is approved to a Standard applicable to the appliance.

This model water heater is categorised as a 'stationary Class 1 motor operated appliance' and satisfies the requirements of AS/NZS 60335.2.40 for leakage current and electric strength. Therefore, this model water heater complies with the insulation resistance requirements of AS/NZS 3000.

ELECTRICAL CONNECTION

The electrical connections between the heat pump module and storage tank are made using mating connectors fitted to these components. This procedure is outlined in "[Heat Pump and Tank Assembly](#)" commencing on page 14.

Refer to the Owner's Guide and Installation Instructions supplied with the heat pump storage tank for information on the connection of the power supply to the water heater.

Note: This water heater must not be connected via a power switching device which allows alternative supply of grid power and photovoltaic (PV) power. The switching of the supplies will cause the water heater to enter a forty five (45) minute start delay mode. Repeated switching will reduce the available heating time for the water heater and can result in an insufficient hot water supply.

WIRING DIAGRAM

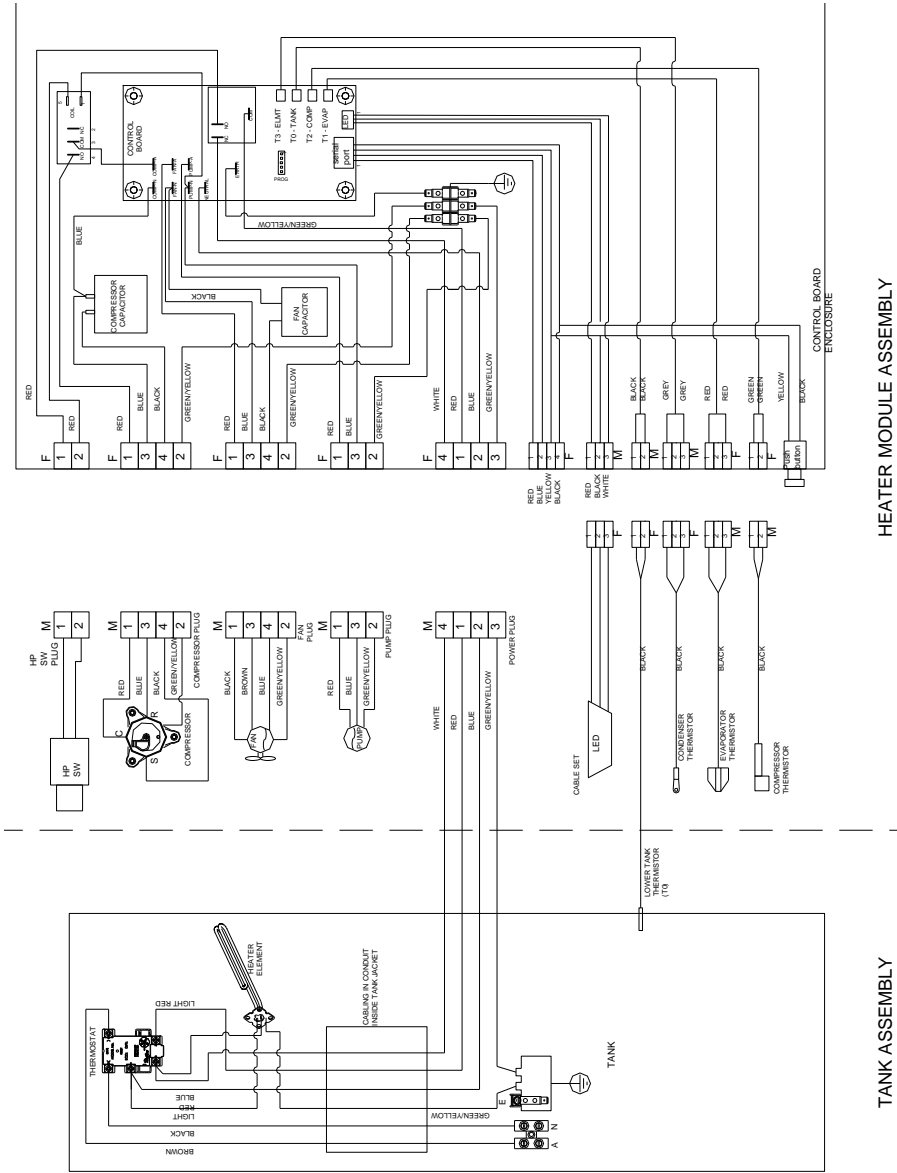

Electrical Circuit for Heat Pump – Robertshaw “ST” Thermostat

COMMISSIONING

TO FILL AND TURN ON THE WATER HEATER

The power supply to the water heater must not be switched on until the water heater is filled with water and a satisfactory megger reading is obtained.

- Open all of the hot water taps in the house (don't forget the shower).
- Open the cold water isolation valve fully to the water heater.

Air will be forced out of the taps.

- Close each tap as water flows freely from it.
- Check the pipe work and the connection points for the flexible braided hoses for leaks
- Inspect for leaks at the temperature pressure relief valve connection to the water heater.

If a leak is detected, close the cold water isolation valve fully and relieve pressure from the water heater by either operating the easing lever on the temperature pressure relief valve or opening a hot tap. Remove the valve and all of its thread sealant from the threads of the valve. Reapply new thread sealant and refit the valve. Refer to the procedure in "Temperature Pressure Relief Valve" in the Owner's Guide and Installation Instructions supplied with the heat pump tank.

- Operate the easing lever on the temperature pressure relief valve to check the smooth operation of the valve plunger and that water discharges freely from the drain line. It is very important the lever is raised and lowered gently. The lever should move smoothly and without undue force.

If the lever cannot be moved or is jerky in its movement, then the valve has been damaged and must be replaced.

- Switch on the electrical supply at the water heater isolating switch on the switchboard and at the isolating switch at the water heater.
- Set the timer if one is installed.

If it is necessary to adjust the outlet temperature of a RheemPlus model, refer to "Outlet Temperature Compensation Adjustment – RheemPlus" in the Owner's Guide and Installation Instructions supplied with the heat pump storage tank.

Note: The water heater is preset in the factory to allow it to commence operating with either the heat pump or booster heating unit immediately power is turned on for the first time. If power is turned on and then off at its installation, the water heater may take up to forty five (45) minutes to commence operating when the power supply is switched on again. This forty five (45) minute period can be overridden during the commissioning procedure if the power was inadvertently turned on and then off again. Refer to “System Reset” on page 36.

The heat pump will only operate when power is available at the water heater, the water in the storage tank requires heating, the heat pump compressor is cool and the ambient air temperature is within the heat pump’s operating temperature range of between a minimum of 3°C to 5°C and a maximum of 45°C to 55°C. If the ambient temperature is outside of this range, the water heater will commence heating with the booster heating unit.

When the heat pump is operating, the system will switch to the booster heating unit if the detected ambient air temperature is outside the operating temperature range of between a minimum of 3°C to 5°C and a maximum of 45°C to 55°C.

The system will not switch back to heat pump operation from the booster heating unit if the detected ambient air temperature has moved back within the heat pump’s operating temperature range. The heating cycle will be completed by the booster heating unit.

Note: The heat pump may not turn on after either having just completed a heating cycle and more hot water is drawn from the water heater or power is shut down to the compressor, either during or at the end of a heating cycle. The heat pump will wait until the compressor has cooled down and the conditions for start-up are favourable in order to protect the compressor from damage. This will be a minimum of forty five (45) minutes and may take up to ninety (90) minutes from the last heating cycle.

It is important to wait for five (5) minutes after the heat pump has activated to ensure it continues to operate and is functioning correctly.

Explain to the householder or a responsible officer the functions and operation of the heat pump water heater. Upon completion of the installation and commissioning of the water heating system, leave this guide with the householder or a responsible officer.

TO TURN OFF THE WATER HEATER

If it is necessary to turn off the water heater on completion of the installation, such as on a building site or where the premises are vacant, refer to “[To Turn Off the Water Heater](#)” on page 7.

DIAGNOSTIC FEATURES OF THE HEAT PUMP CONTROLLER

An operating mode monitor is located on the front of the heat pump module and houses a green and a red LED.

The green LED, marked “NORMAL”, indicates the current operating mode (with the red LED off) of the heat pump water heater and the red LED, marked “ATTENTION”, may indicate a potential fault mode.

The green LED will emit either a constant glow or a series of flashes, with a two (2) second interval between each series. A series of long green flashes may also be emitted.

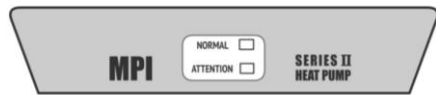

The red LED will emit either a solid glow or a series of flashes, with a two (2) second interval between each series. A series of flashes indicates there may be a particular fault condition with the system.

The modes are:

Flashes	Operational Modes
solid green (remains on)	Standby mode – water is hot
1 x green	Call for heating received – system checks performed Note: unit may wait and continue flashing until compressor has cooled from its last operation
2 x green	Heat pump preheating
3 x green	Heat pump operation – compressor and fan running
4 x green	Freeze protection operation – circulator on
long green	Heating unit on – ambient air temperature below 3°C to 5°C or above 45°C to 55°C
rapid green	System start-up – heating unit on
no green (remains off)	No power at the water heater or to the heat pump or a possible fault condition Refer to notes overleaf before calling for service

Flashes	Indicator or Fault Modes	
1 x red	Heating unit on	compressor over temperature (possible circulator fault)
3 x red	Heating unit on	compressor cooling fault condition
4 x red	Heating unit on	tank thermistor fault condition
5 x red	Heating unit on	evaporator thermistor fault condition
6 x red	Heating unit on	compressor thermistor fault condition
7 x red	Heating unit on	heat exchanger water outlet sensor fault
8 x red	Heating unit on	water flow fault condition
9 x red	Heating unit off	refrigeration system (compressor) fault condition Call for service
solid red (remains on) + solid green (remains on)	Heating unit off	system reset – release button

Notes

- **There is no 2 x red flash indicator or fault mode code.**
- **Power must be available at the water heater and to the heat pump for the LEDs to glow or flash.**
- **Time controlled power supply (power must be available at the water heater)**

If the water heater is connected to a time controlled power supply, then during periods of no power supply at the water heater the LEDs will be off.

This is not a fault condition, but a result of no power being available to energise the LEDs.

The green LED will recommence glowing or flashing when power is available again at the water heater.

- **Heat pump operating range (power must be available to the heat pump)**
The heat pump's operating range is between an ambient air temperature of a minimum of 3°C to 5°C and a maximum of 45°C to 55°C. The heat pump will not operate when the ambient air temperature is outside the heat pump's operating range.

If heating is required, the water heater will commence heating with the booster heating unit in booster heating mode (long green flash) instead. The water will be heated to 70°C during these periods.

At the completion of this heating cycle by the booster heating unit (long green flash), the thermostat controlling the booster heating unit opens circuit cutting power to the heat pump causing the green LED to go out. This is not a fault condition, but a result of the power being cut to the heat pump by the thermostat.

Refer to "Heat pump operating range" in the "Save A Service Call" section of the Owner's Guide and Installation Instructions supplied with the heat pump storage tank for further explanation.

- **Possible fault condition**
If there is power to the water heater and the green LED is off or the red LED is flashing, this indicates there may be a fault condition with the water heater. The red LED may emit up to nine flashes in each series of flashes.

There may be a fault condition with the water heater if either:

- there is power available at the water heater and the green LED is off, and

- the water heater **has not** operated outside of the heat pump’s operating range.

Before phoning to arrange a service inspection due to the green LED being off, refer to “Heat Pump Is Not Operating” in the “Save A Service Call” section of the Owner’s Guide and Installation Instructions supplied with the heat pump storage tank.

or

- the red LED is flashing – the red LED may emit up to nine (9) flashes in each series of flashes

The fault condition which led to the red LED flashing may be cleared after the backup heating cycle by the booster heating unit has completed. When heating is next required the red LED will recommence to flash the fault code for 27 seconds and then extinguish. If the red LED then recommences to flash or recommences to flash after the heat pump next operates, a service call may be required.

Before phoning to arrange a service inspection due to the red LED flashing, refer to “Heat Pump Is Not Operating” in the “Save A Service Call” section of the Owner’s Guide and Installation Instructions supplied with the heat pump storage tank.

SYSTEM RESET

To reset the system and override the forty five (45) minute start delay:

- Press and hold the red controller reset button for two (2) to three (3) seconds until both the green and red LEDs display a solid glow. Release the button.

The reset button is located on the front left corner of the underside of the controller box.

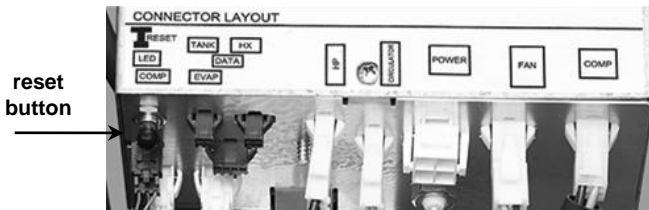

- The green LED will flash rapidly for three (3) seconds, then the heat pump will commence its heating start-up cycle. A series of 2 or 3 x green flashes will commence.

WATER SUPPLIES

This water heater must be installed in accordance with this advice to be covered by the manufacturer's warranty.

This water heater is manufactured to suit the water conditions of most public reticulated water supplies. However, there are some known water chemistries which can have detrimental effects on the water heater and its operation and / or life expectancy. If you are unsure of your water chemistry, you may be able to obtain information from your local water supply authority. This water heater should only be connected to a water supply which complies with these guidelines for the manufacturer's warranty to apply.

CHANGE OF WATER SUPPLY

The changing or alternating from one water supply to another can have a detrimental effect on the operation and / or life expectation of a number of components in this water heater.

Where there is a changeover from one water supply to another, e.g. a rainwater tank supply, bore water supply, desalinated water supply, public reticulated water supply or water brought in from another supply, then water chemistry information should be sought from the supplier or it should be tested to ensure the water supply meets the requirements given in these guidelines for the manufacturer's warranty to apply.

SATURATION INDEX

The saturation index (SI) is used as a measure of the water's corrosive or scaling properties. The saturation index figures stated are calculated using a water temperature of 80°C.

Where the saturation index is less than -1.0 , the water is very corrosive and the manufacturer's warranty does not apply to the water heater. In a corrosive water supply, the water can attack copper parts and cause them to fail.

Where the saturation index exceeds $+0.40$, the water is very scaling and the manufacturer's warranty does not apply to the water heater.

Water which is scaling may be treated with a water softening device to reduce the saturation index of the water.

CHLORIDE AND PH

Where the chloride level exceeds 250 mg/L the manufacturer's warranty does not apply to the water heater. In a high chloride water supply, the water can corrode stainless steel parts and cause them to fail.

Where the pH is less than 6.0 the manufacturer's warranty does not apply to the water heater. pH is a measure of whether the water is alkaline or acid. In an acidic water supply, the water can attack stainless steel parts and cause them to fail.

Water with a pH less than 6.0 may be treated to raise the pH. The water supply from a rainwater tank in a metropolitan area is likely to be corrosive due to the dissolution of atmospheric contaminants.

SUMMARY OF WATER CHEMISTRY ADVICE AFFECTING WARRANTY

The water heater, including this heat pump module, is not suitable for certain water chemistries. Those chemistries are listed below. If the water heater is connected at any time to a water supply with the following water chemistry, the manufacturer's warranty will not cover any resultant faults:

Water Chemistry

Saturation Index (SI) < -1.0

Saturation Index (SI) > +0.4

Chloride > 250 mg/L

pH < 6.0

Refer to "Water Supplies" in the Owner's Guide and Installation Instructions supplied with the storage tank for the complete water supply statement.

WARRANTY NOTE

The heat pump water heater is covered by the manufacturer's warranty. For full manufacturer's warranty details, refer to the Owner's Guide and Installation Instructions supplied with the storage tank.

The part extracts from the "Terms Of The Warranty And The Exclusions To It" of the water heater warranty should be noted before commencing the installation.

TERMS OF THE WARRANTY AND EXCLUSIONS TO IT

- 2.5 Where the water heater is installed in a position that does not allow safe or ready access, the cost of that access, including the cost of additional materials handling and/or safety equipment, shall be the owner's responsibility. In other words, the cost of dismantling or removing cupboards, doors or walls and the cost of any special equipment to bring the water heater to floor or ground level or to a serviceable position is not covered by this warranty.
- 2.7 The warranty does not cover faults that are a result of:
- c) Installation not in accordance with the Owner's Guide and Installation Instructions or with relevant statutory and local requirements in the State or Territory in which the water heater is installed.
 - d) Connection at any time to a water supply that does not comply with the water supply guidelines as outlined in the Owner's Guide and Installation Instructions.
 - k) Ice formation in the waterways of a water heater system incorporating a freeze protection system where the electricity supply has been switched off or has failed.
- 2.8 Rheem may reject a claim under this warranty in its sole discretion if a third party solar diverter is connected to the water heater.
- 2.9 Subject to any statutory provisions to the contrary, this warranty excludes any and all claims for damage to furniture, carpet, walls, foundations or any other consequential loss either directly or indirectly due to leakage from the water heater, or due to leakage from fittings and/ or pipe work of metal, plastic or other materials caused by water temperature, workmanship or other modes of failure.

